

### 1416 & 1517 Style Steel Service Punch Tee Installation Instructions 1 1/4" IPS & Larger Steel Mains x Compression Outlet for 1 1/4" IPS PE Pipe

1. Before installing the service tee, confirm the punch is rated for the steel pipe to be tapped.
  - 3/8" tip punches are rated for 0.280" maximum wall thickness and 70 ksi maximum yield strength.
  - 1/4", 1/2", 3/4" & 1" tip punches are rated for 0.250" maximum wall thickness and 65 ksi maximum yield strength.
2. Verify that the compression outlet on the service tee is the correct size for the polyethylene (PE) pipe. Verify the SDR (or wall thickness) of the pipe matches the SDR (or wall thickness) stamped on the end of the stiffener.
3. Clean the main of all coatings, rust, dirt, etc., in the area where the saddle is to be installed. The elastomer seal should not be installed over pits or gouges in the pipe where the sealing integrity might be compromised.
4. Remove saddle bolt and place saddle in the desired position.
5. Replace saddle bolt and tighten leak tight, taking care not to rotate saddle on the main. It is recommended that the bolt be tightened between 25 to 40 foot pounds of torque.  
**DO NOT OVER TORQUE BOLT.**
6. Make the service connection. See other side for outlet assembly instructions.
7. To assure proper assembly and to comply with 49 CFR 192 Subpart J—Test requirements, the joint shall be leak tested.
8. **Lubricant must be applied to the punch threads and punch tip.** Acceptable lubricants include thread cutting oil, tapping fluid or tapping grease.
9. Insert punch in service tee and turn clockwise by hand to avoid cross threading.
10. Use a ratchet wrench with Continental drive key and bushing to make the tap.
  - For 1" body tees, use 23-0941-00 Square Drive Key, Bushing & Socket Adapter
  - For 1 1/4" body tees, use 23-0940-00 Square Drive Key, Bushing & Socket Adapter

**IMPORTANT:** To insure retention of the coupon - coupon retaining punches should be run all the way down until the punch seats on the main.

11. To allow gas to the service line, back punch up until it is flush with the top of the tee.
12. Apply thread sealant and install pipe cap leak tight.

**NOTE:** If desirable at a later date, the service may be interrupted by running the punch valve down until it seats on the main.

#### IMPORTANT

**For use on:**

Polyethylene (PE) gas pipe meeting the requirements of ASTM D 2513

**Pressure Rating:** Designed to meet or exceed pressure rating of PE pipe per 49 CFR Part 192 and ASTM D 2513

**Operating Temperature:** -20 to 140° F

**Material:** Carbon Steel

## Compression Outlet for 1 1/4" IPS PE Pipe Installation Instructions

1. Loosen the compression nut.
2. Cut polyethylene pipe end square, deburr inside and outside, clean thoroughly to assure there is no dirt, grease, oil, etc. on assembly area of pipe.
3. Mark stab length on pipe (see example for correct pipe or tubing size and corresponding stab length).

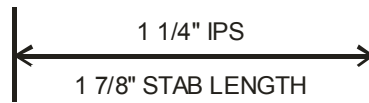

4. Insert the polyethylene pipe through the compression nut until it bottoms in the outlet.
5. Tighten compression nut to approximately 90 ft. lbs. The stab length line should be no more than 5/8" from face of the compression nut. (See below)
6. If the stab length line is more than 5/8" from the face of the compression nut, disassemble the joint and repeat steps 1 through 5.

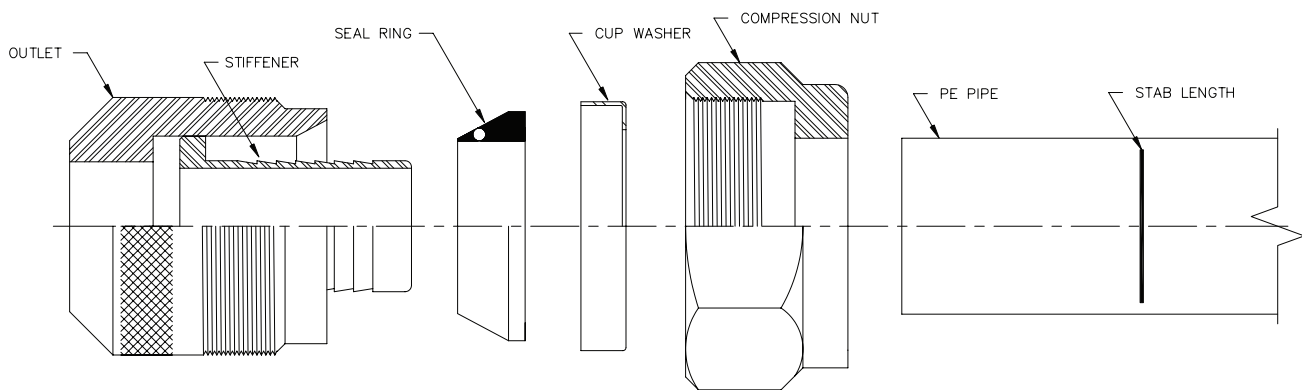

ORDER OF PARTS FOR 1 1/4" IPS PE COMPRESSION OUTLET

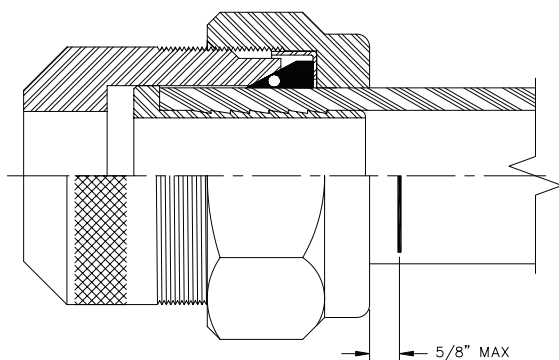

**NOTE:** It is advisable to limit shear at main connections. In this regard, your company's policies should be followed. For further information, reference; ASTM D 2774 Standard Practice for Underground Installation of Thermoplastic Pressure Piping; Code of Federal Regulations, Title 49, Transportation Part 192; AGA Plastic Pipe Manual and/or The Guidance Manual for Operators of Small Gas Systems by the U.S. Department of Transportation.